

BALLANTINE TRENCH-ALL[®] CHAIN

*The only Chain Engineered
Specifically for Trenchers*

Ranging from 7 H.P. to 750 H.P. machines

Attachment Side Plates
Alloy Steel, specially hardened,
with bolt on design for attaching
various types of cutters.

Roller Link Side Plates
Alloy Steel, specially
hardened to provide high
strength and toughness, while
still providing wear resistance
from boom contact.

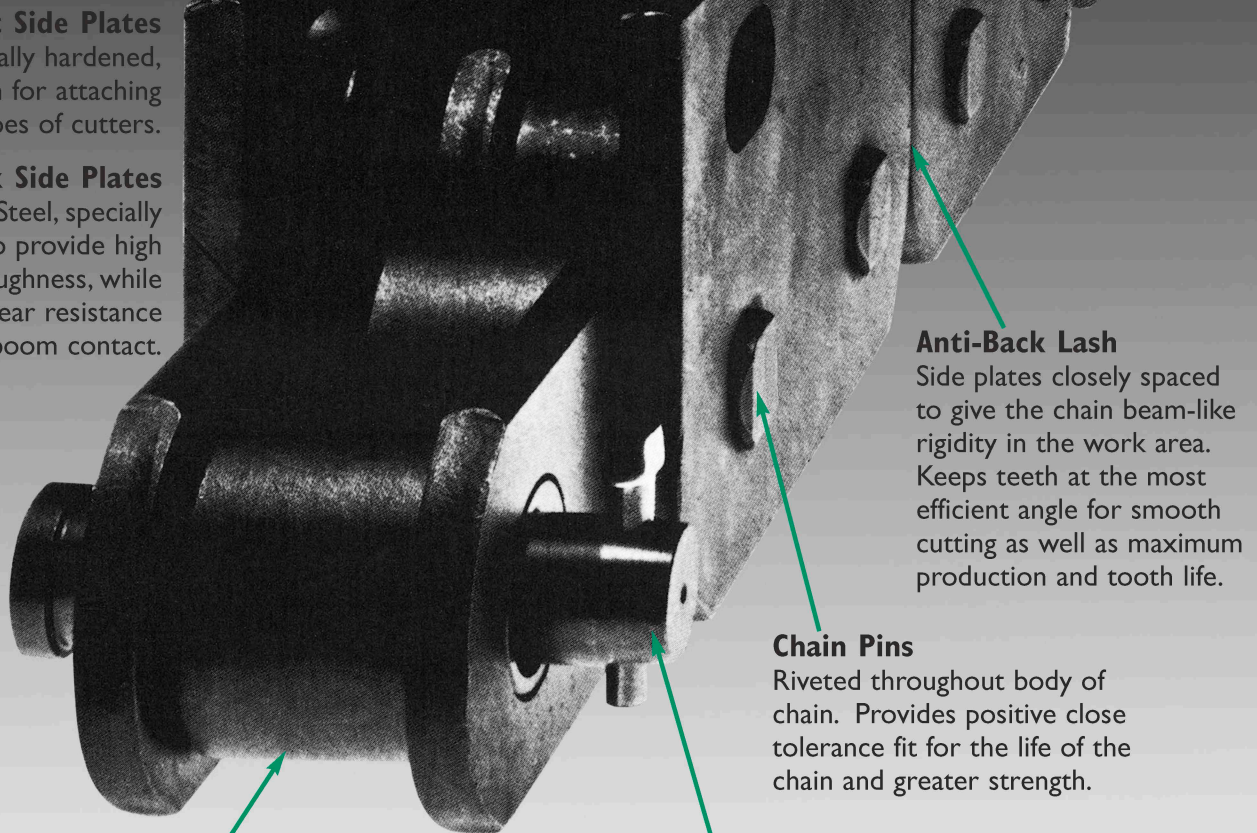

Roller
Alloy Steel, hardened to
provide additional wear life
and greater strength.

Chain Pins
Riveted throughout body of
chain. Provides positive close
tolerance fit for the life of the
chain and greater strength.

Connector Pin
Specially produced alloy steel,
hardened to provide the best
combination of strength, toughness,
and wear resistance. Formed to press
fit into connecting side plates for
greater fatigue strength.

Anti-Back Lash
Side plates closely spaced
to give the chain beam-like
rigidity in the work area.
Keeps teeth at the most
efficient angle for smooth
cutting as well as maximum
production and tooth life.

BALLANTINE
TRENCH-ALL[®]
CHAIN

BALLANTINE
TRENCH-ALL[®]
TEETH

BALLANTINE
TRENCH-ALL[®]
SYSTEMS

BALLANTINE TRENCH-ALL® SYSTEMS

There's a reason that utilities, contractors and rental stores across the country are using BALLANTINE TRENCH-ALL® Digging Chain and Accessories.

BALLANTINE TRENCH-ALL® CHAIN IS BETTER!

Why? More steel, closer tolerances, no back lash (for **smoother operation** and less wear on your equipment, **fuel economy** with less horsepower required to turn the chain, and **more production** with rigid chain keeping cutters at the proper attack angle). High carbon alloy material and thru-hardened heat treatment add to chain life.

What does this mean to you? On an average, **twice the life** compared to all other replacement or original equipment chains.

For your field work, this means **less downtime** which **saves you labor dollars**.

Even without the labor and time factor, by lasting twice as long,
BALLANTINE TRENCH-ALL®
costs less to use—just comparing replacement costs.

BALLANTINE TRENCH-ALL® chains keep working two, sometimes three times longer than our competitors.



Does it really save money to buy the cheapest?



With TRENCH-ALL®, it really is less expensive to buy **The Very Best!**

DIGGING CHAIN, TEETH, SPROCKETS AND PLOW BLADES

Standard replacement or custom design

BALLANTINE TRENCH-ALL® chains are ready to handle all of your needs in most any soil condition.



Manufactured as replacement for all major brand trenching machines from 7 H.P. to 750 H.P.

Sprockets

High carbon alloy steel — Flame cut to insure pitch accuracy for maximum roller area to tooth area contact — thru-hardened heat treatment.

